



The Explanation for Certain Cathode-Follower Effects

ONE of the problems when using a high-impedance voltmeter to measure voltage in high-impedance audio and video-frequency circuits is minimizing the effect of test lead capacity. Usually, shielded test leads are necessary to prevent hum pick-up, but the capacity of such leads is likely to load seriously the circuit under test. For example, a set of shielded test leads may add 100 micro-

SEE PAGE 3 FOR A DESCRIPTION OF THE NEW 500-VOLT, 200 MA REGULATED POWER SUPPLY.

micro-farads to the circuit under test. This represents a reactive loading at 10 kc of 160,000 ohms—a very appreciable loading across a one-half or one megohm circuit.

A review of the literature pertaining to this problem shows that the usually-recommended panacea is the use of a cathode-follower input with a shielded cable connected between grid and cathode. This connection divides the input capacity roughly by the feedback factor of the cathode follower. Resistance-wise, the grid resistor can be connected so that its value will be increased by the same feedback factor, making obtainable an input impedance as high as 100 megohms.

At first, this arrangement seems an almost ideal solution to the problem, but examination of the circuit discloses major shortcomings. Consider Figure 2 which shows the cathode-follower used as an impedance-transformer between a high-impedance stage and a measuring instrument. A double-shielded cable is used in the input circuit to minimize hum pick-up. The output circuit is shown to include the capacity of the test lead to the measuring equipment as well as the input capacity of the measuring equipment itself.

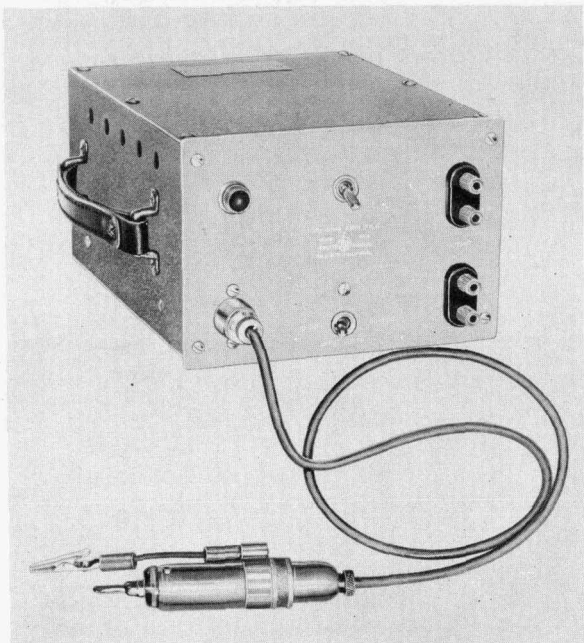

Figure 1. Model 451A Bridging Amplifier has 83-megohm positive input impedance.

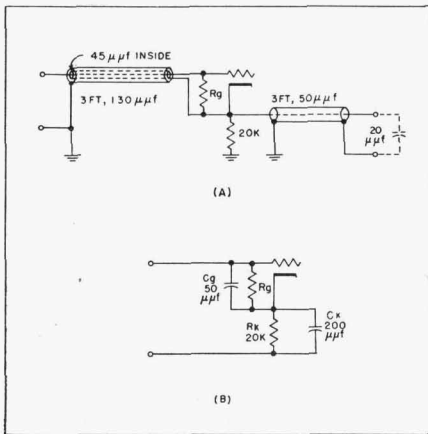

Figure 2. (a) Cathode follower used as impedance transformer. (b) Same circuit with capacities lumped.

A mathematical investigation shows that the circuit of Figure 2(b) has the approximate equivalent circuit shown in Figure 3(a). This equivalent circuit includes *negative* capacity components as well as a *negative* resistance component. In other words the impedance-transforming cathode-follower amplifier of Figure 2 is itself a voltage generator and will feed energy back into the circuit being measured under certain conditions.

Evaluating the circuit of Figure 3(a), it will be seen that at very low frequencies the resistances R_1 and R_2 normally become insignificant compared to the reactances of the capacitors in the upper portion of the branch. This therefore leads to the equivalent circuit shown in Figure 3(b). Here the negative capacities $-C_g$ and $-C_k$ are exactly compensated by the positive capacities C_g and C_k . Hence, the input circuit of the cathode follower consists of (a) the grid resistance multiplied by the feedback factor of the cathode follower (b) in parallel with the grid capacity divided by the feedback factor (Figure 3(c))—all according to conventional theory.

However, as frequency increases and the reactance of the negative ca-

pacities becomes less, the negative resistance component becomes more influential. The effect of the cathode follower's negative impedance can often be observed by connecting the circuit of Figure 2 across an inductance, for all the conditions necessary for oscillation are then present and the circuit will frequently oscillate for a wide range of inductance values. In a voltage-measuring application, this oscillation will completely prevent any real measurement of voltage. If the circuit is connected across other than an inductance, the action of the cathode follower may increase the voltage at the point of measurement, also giving inaccurate results.

Another facet of the impedance of cathode followers involves the load that is driven by the cathode circuit. If the input impedance of the cathode follower is to be made reasonably high, a relatively high value of cathode resistance is desirable. If, at the same time, the low output impedance of the cathode follower is to be used to drive a low-impedance load, the effective value of the cathode resistor is reduced. This reduction may easily be as much as two to one. The lowered effective value of

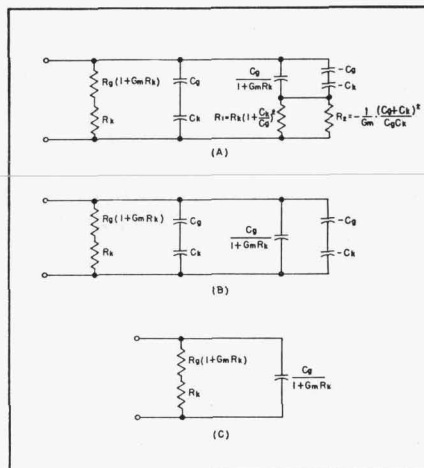

Figure 3. (a) Equivalent circuit of Figure 2. (b) and (c) Low frequency equivalent circuit.

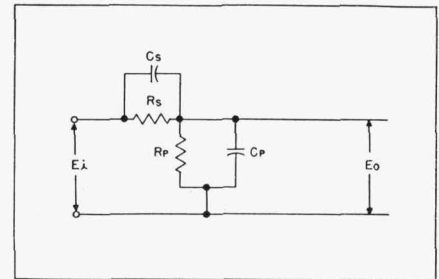

Figure 4. Resistance-capacity voltage divider.

cathode resistance will then be reflected in a reduction in input impedance by this same factor, for the input impedance is proportional to $(1+G_m R_k)$. In other words the cathode follower can be used to obtain a high input impedance or a low output impedance, but full advantage cannot be taken of both characteristics at the same time.

For the above reasons the cathode follower is not considered to be a satisfactory solution to the original problem, which was to reduce the effect of the capacity of the test leads in combination with the capacity of the measuring equipment. Another approach that eliminates the cathode follower and still achieves this objective is the simple resistance-capacity voltage divider shown in Figure 4.

In Figure 4 if the ratio of the capacities equals the ratio of the resistances ($C_p/C_s=R_s/R_p$), the voltage divider action is constant at all frequencies ($E_o/E_i=R_p/(R_p+R_s)$). To solve the original problem, the divider of Figure 4 can be designed to use the capacity of a test cable as part of the voltage divider, as in Figure 5. Here, the capacity C_p is the capacity of the shielded cable and has been absorbed into the circuit so that it is useful. By properly choosing R_s and the length and type of cable, and by taking care to avoid excess capacity in the shield around R_s , a test lead with an input impedance of low capacity and high resistance is ob-

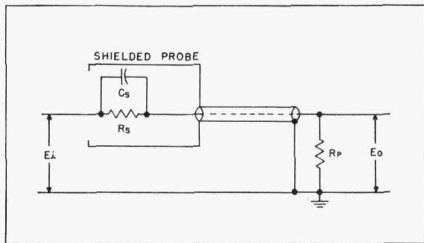

Figure 5. R-C divider incorporated into high-Z probe.

tainable. Thus, it is possible to make the input resistance $R_s + R_p$ well over 50 megohms and to keep the total input capacitance within approximately 5 mmf.

To compensate for the loss in voltage caused by the voltage divider action, a good amplifier whose gain is stabilized by feedback at a value inversely related to the reduction in the voltage divider (E_o/E_i) can be connected across the output of the divider. We then have a one-to-one circuit that can be connected between the test point and any of the usual pieces of measuring equipment ordinarily on hand. This arrangement is the substance of the -hp- Model 451A Bridging Amplifier.

With about a 15:1 reduction in the voltage divider, this circuit can only exhibit a fixed positive input resistance. If the amplifier is properly designed, it introduces negligible error into the system. Further, the output impedance of the amplifier can be made even lower than that of the cathode follower. Owing to the isolation by the input divider, any excessive loading of the amplifier output can not affect the circuit under test.

The -hp- 451A is designed in the above manner and provides the desirable features of a shielded input cable with a low-capacity, high-resistance input and a low-impedance output system, all at moderate cost. Any of the usual pieces of test equipment can then be connected to its output. The input capacity is approximately 5 mmf and the input resistance in excess of 83 megohms over the range from 20 cps to 200 kc. Distortion produced in the amplifier is less than 0.1% up to 30 volts output. To permit measurement of voltages higher than 30, a switch in the unit increases the loss in the input divider circuit by a factor of 10, al-

lowing voltages up to 300 to be measured at an overall gain of one-tenth. The frequency response is flat within 2% from 20 cps to 200 kc and within 1 db from 20 cps to 1 mc. Hum and noise across the output terminals are less than 4 millivolts. Two sets of output terminals permit monitoring of the test voltage by two different measuring instruments.

—Brunton Bauer.

**SPECIFICATIONS FOR -hp-
MODEL 451A BRIDGING AMPLIFIER**

FREQUENCY RESPONSE: Constant within 2% from 20 cps to 200 kc; constant within 1 db from 20 cps to 1 mc.

INPUT IMPEDANCE: Approximately 83 megohms shunted by 5 mmf.

INPUT VOLTAGE RANGE: Up to 30 volts at gain of unity; up to 300 volts at gain of one-tenth.

MAXIMUM OUTPUT VOLTAGE: 30 volts.

DISTORTION: Less than 0.1% from 20 cps to 200 kc when loaded with 0.1 megohm or more.

OUTPUT NOISE: Less than .004 volts including hum.

OUTPUT IMPEDANCE: Less than 5 ohms above 5 kc.

POWER SUPPLY: Operates from nominal 115 v, 50/60 cycle source; requires 40 watts.

CABLES SUPPLIED: Input probe and cable permanently attached; 7' power cable permanently attached.

DIMENSIONS: 8 1/2" wide, 5 1/2" high, 11" deep.

WEIGHT: Approx. 9 lbs.; shipping weight, 22 lbs.

PRICE: \$100 f.o.b. Palo Alto, California. Data subject to change without notice.

Extended-Range Metered Power Supply

The popular -hp- Model 710A regulated power supply was designed as a low-power source and has proved very useful for general laboratory applications. Now, in accordance with requests for a regulated supply with higher voltage and current capacity, the new -hp- Model 712A has been designed. This economical supply is useable in applications where regulated dc voltages up to 500 volts at currents up to 200 milli-

amperes are required. Both the output voltage and current are directly indicated by large 4-inch panel meters. A regulated 0-150 volt negative dc adjustable bias supply and ac filament power are also provided. Current overload fuses are located in convenient panel mounting posts.

The high-voltage supply is adjustable from 500 volts down to less than 1 volt in one continuous sweep and regulates within 0.5% or 0.1 volt,

whichever is larger, from no-load to full-load. The negative terminal of the high-voltage supply is connected internally to the positive terminal of the bias supply so that the bias supply is always negative with respect to the negative terminal of the high-voltage supply. However, either the positive or negative terminal of the high-voltage supply can be grounded. The panel voltmeter that monitors the high-voltage has two ranges,

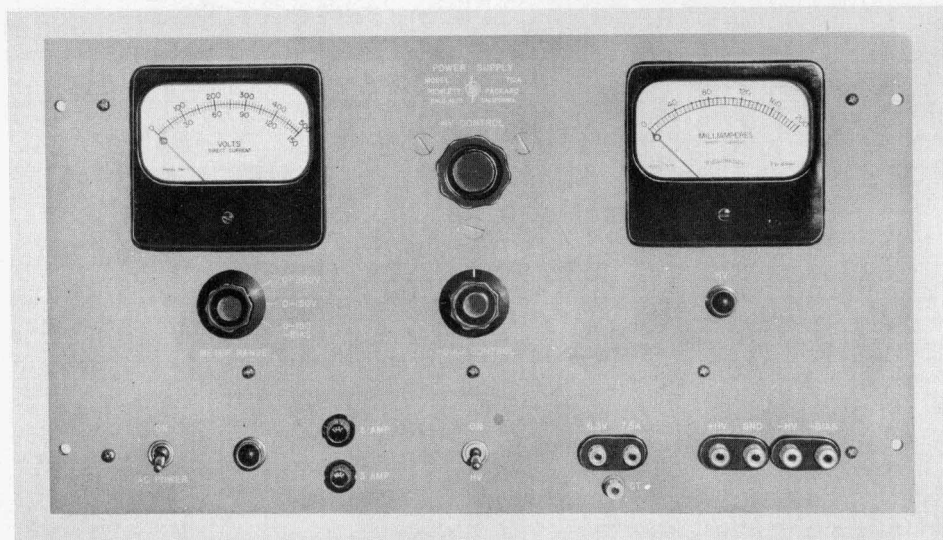

-hp- Model 712A Regulated Power Supply provides regulated voltages adjustable from 0-500 volts at currents up to 200 ma.

0-150 vdc and 0-500 vdc, to permit greater accuracy in setting output voltages. The current from the high-voltage supply is read on a 0-200 milliamper meter.

The bias supply is adjustable up to -150 volts dc and will provide currents up to 5 ma. At maximum voltage, regulation is within 1% from no-load to full-load. In the worst condition, the internal impedance of the bias supply is approximately 6500 ohms. However, the 0-150 volt range of the panel voltmeter can be switched to the bias supply to permit accurate adjustment of bias voltage.

The filament supply provides 6.3 volts ac at currents up to 10 amperes maximum. Regulation of the filament supply is not provided. A center-tap on the transformer winding for the filament supply is brought out to the front panel to be grounded when desired. The filament winding can be operated at dc voltages up to approximately 500 volts, depend-

ing upon the external circuit.

The -hp- 712A has been designed for reliability and long trouble-free performance. Oil-filled paper capacitors are used instead of electrolytics. By means of a special circuit arrangement, the control tubes in the circuit are operated at only about

75% of rated plate dissipation, whereas, in this type circuit the plate dissipation of the control tube usually is a limiting factor. The above features combined with the moderate price of the -hp- 712A make it well adapted to general-purpose work.

**SPECIFICATIONS FOR MODEL 712A
REGULATED POWER SUPPLY**

OUTPUT VOLTAGE No. 1: Regulated; 0-500 volts dc without switching; 200 ma maximum load.

OUTPUT VOLTAGE No. 2: Regulated; 0-150 volts dc negative; 5 ma maximum load.

OUTPUT VOLTAGE No. 3: Unregulated; 6.3 volts ac center-tapped; 10 amperes maximum load.

REGULATION: HV No. 1, within 0.5% or 0.1 volt, whichever is larger, from no load to full load at any line voltage from 105 to 125 volts. HV No. 2, within 1% from no load to full load at maximum output voltage. Regulation at other voltages depends on setting of voltage control; internal impedance may be as high as 6500 ohms.

METERS: Current, 0-200 ma. Voltmeter, 2 ranges, 0-150 and 0-500 volts. 0-150 volt range can be switched to read HV No. 2 output voltage.

HUM: Less than 8 millivolts.

TERMINALS: Either positive or negative terminal of HV No. 1 can be grounded. Positive terminal of HV No. 2 is internally connected to negative terminal of HV No. 1.

INPUT POWER: Operates from 105-125 volt, 50/60 cycle supply; requires approximately 400 watts.

OVERLOAD PROTECTION: Load and line separately fused. Fuses available on front panel.

MOUNTING: Relay rack mounting; end frames are available to convert to table mounting but are not essential.

SIZE: 10½" high, 19" wide, 13" deep.

WEIGHT: 60 lbs. Shipping weight, approx. 110 lbs.

PRICE: \$250.00 f.o.b. Palo Alto, Calif. End frames \$5.00 per pair f.o.b. Palo Alto, Calif. (Specify No. 17.)

Data subject to change without notice.